

Erosion protection of a surface water drainage channel at Park Farm, Ashford.

Location:	Park Farm, Ashford, Kent, UK
Client:	Park Farm - Ashford
Designer:	Frank Graham & Partners
Contractor:	Natta Construction Ltd.
Product:	TENAX MULTIMAT 100 Three-dimensional geomats

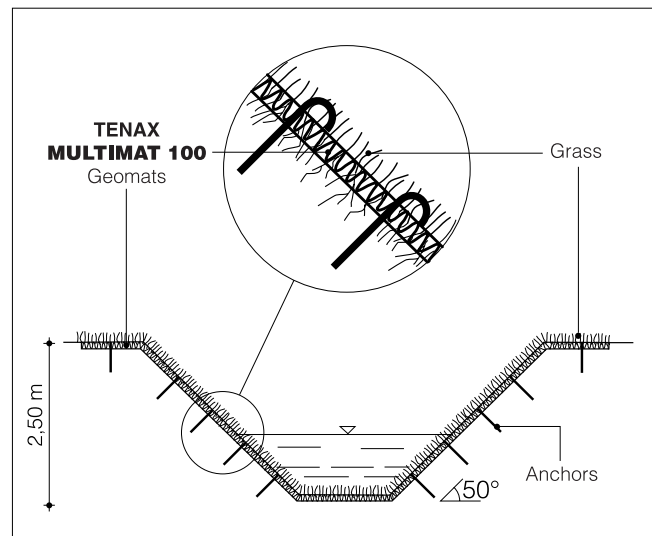

The Problem

A 1000 m long drainage channel was required to remove surface water during construction of the largest housing estate in the South East of England, at Park Farm, Ashford. The channel was to be constructed as part of the infrastructure programme for the residential development being undertaken by Park Farm (Ashford) Ltd. (a subsidiary of Pelham Homes Ltd.) and Mountleigh Plc.

Above: Schematic cross section of the channel.
On the right: Filling of the geomat with organic soil.



The site three months after hydroseeding.

The Solution

A concrete culvert was contemplated, but due to both costs and aesthetics, this was rejected in favour of a grassed earth channel that would be more in keeping with the surrounding countryside.

Due to the high water run off from the 130 hectare site, the consultants, Frank Graham & Partners specified the use of an erosion control geomat to both stabilize the slope and alleviate scour of the channel itself. The contractor, Natta Construction Ltd. chose to use **TENAX MULTIMAT 100**, a three dimensional U.V. stable polypropylene erosion control mat.

TENAX MULTIMAT 100 was easily installed down the prepared side slopes and the channel bed and secured in place with 400 mm long steel fixing pins spaced every 1 m. The **TENAX MULTIMAT 100** was filled with 20 mm of topsoil and then the drainage channel was hydroseeded to help accelerate the growth of natural vegetation. Once growth has been established the roots entwine with **TENAX MULTIMAT 100** anchoring it to the soil below, thus acting as a permanent reinforcement of the root system.

TENAX MULTIMAT 100 is a three-dimensional geomat composed by three layers of polypropylene grids: two flat, one folded. The random structure of filaments comprising the geomat prevents soil particles migrating, interlocks with the grass roots and reduces the run-off water flow thus preventing erosion.



Completed channel section during the germination process.

Conclusions

The use of **TENAX MULTIMAT 100** geomats allowed:

- A cost effective erosion control system that provided stable channel sides against surface scour;
- A constant long term cross section of the channel and thus a constant hydraulic flow;
- Rapid development of a reinforced grass vegetated banks sides;
- An environmental friendly and aesthetically pleasing channel;
- An increased resistance to hydraulic water flow with minimal erosion, for vegetated slopes, up to a flow rate having a limit velocity of 6.0 m/s.

TENAX MULTIMAT 100 geomats are polypropylene products, studied for protection and growing of grass on slopes subject surface erosion.

TENAX MULTIMAT 100 is produced by means of extruded and bioriented polypropylene grids, laid one upon another and tied up by means of a black polypropylene yarn. A thick structure, made of factory folded grids, is bounded by two layers of flat geogrids, giving high tensile strength, compression resistance and flexibility.

**TENAX
MULTIMAT 100**
Three-dimensional
geomats

DIMENSIONAL CHARACTERISTICS:

Thickness:	17.0 mm
Gross roll weight:	24.0 kg
Roll width:	2.20 m
Roll length:	30.0 m

TECHNICAL CHARACTERISTICS:

Test Method ISO 10319

Peak tensile strength:	
Longitudinal:	10.0 kN/m
Transversal:	15.0 kN/m
Yield point elongation:	
Longitudinal:	20.0%
Transversal:	15.0%

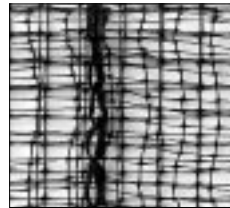

The TENAX Laboratory has been created in 1980 and has been continuously improved with the purpose of assuring unequalled technical development of the products and accurate Quality Control. The TENAX Laboratory can perform mechanical, hydraulic and durability tests, according to the most important international standards like ISO, CEN, ASTM, DIN, BSI, UNI.



The TENAX Quality System is certified in accordance with the ISO UNI EN 9002 Standard.



TENAX International B.V. • Geosynthetics Division

Via Ferruccio Pelli, 14 • CH-6900 Lugano SWITZERLAND
Tel. +41 +91.9242485 • Fax +41 +91.9242489
<http://www.tenax.net> • e-mail: geo@tenax.ch