

Tenax Geonets for Urban Waste Facility for the City of Brescia, Italy



PRODUCT	TENAX CE 204 geonets
LOCATION	Ospitaletto (BS), Italy
OWNER	Brescia City Council Public Service
PROJECT	Aprica Studi - Brescia
CONTRACTOR	Aprica SpA - Brescia

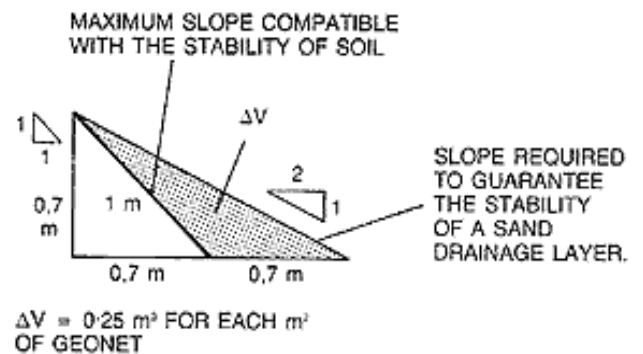

Fig. 1 - Geonets allow to use the maximum allowable slope

Problem

The Brescia city council public service had to extend its own waste disposal system for urban solid waste, situated in Ospitaletto (BS). The waste disposal covers a surface of 180.000 m², 90.000 of which are made up of the old disposal and are already full of waste.

The intention was to carry out the realization of the 2° block (areas B1 and B2) over a surface of little more than 40.000 m² and therefore obtaining an available volume of 1.000.000 m³ for the storage of waste, respecting the Italian law n. 915/82, which regulates waste disposal system.

Solution

In order to obtain the required volume, it was decided to build a 18 m deep tank with sides inclined at 45°, storing the waste even up to about 7 m. over the ground level. For waterproofing and drainage of the bottom and of the sides, the solution shown in Fig. 2 has been chosen.

Taking into account the fact that the ground below consists of very permeable cemented sand and gravel, the safety waterproofing of the bottom has been obtained by a layer of clay of a minimum thickness of 1 m. As it is impossible to lay clay on sides of 45°, a HDPE geomembrane with a minimum thickness of 2 mm has been used, identical to the one used on the bottom and on the sides for the basic water-proofing.

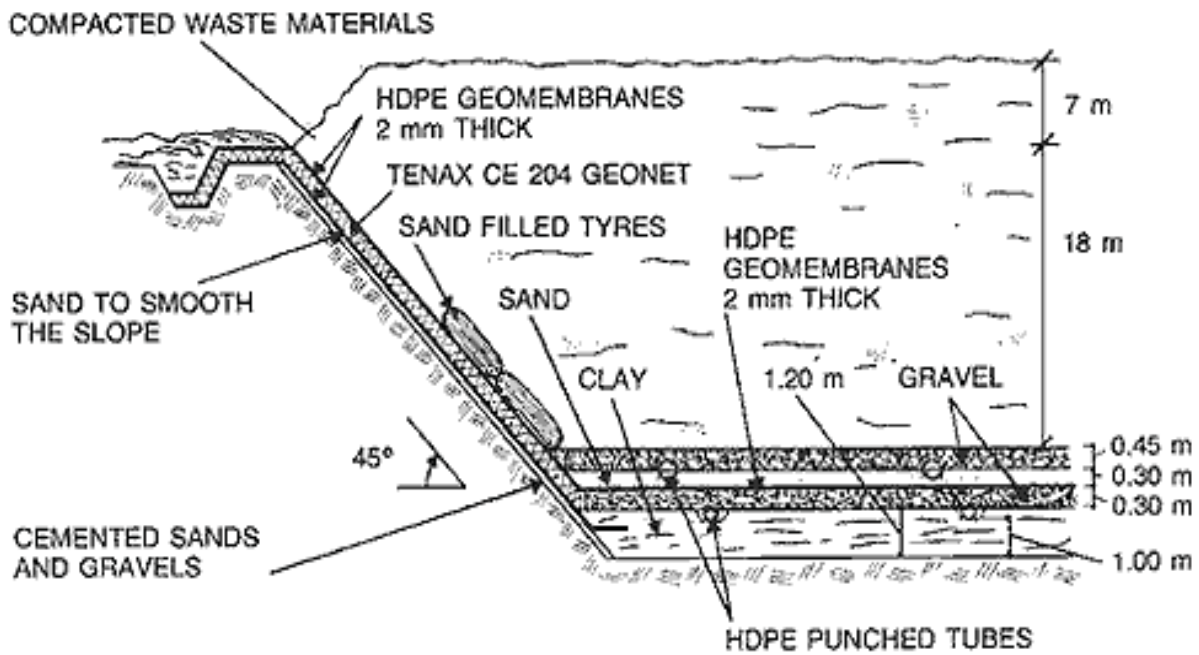

Fig. 2 - Schematic cross-section of the waste disposal

The connection between geomembranes and clay has been carried out as shown in Fig. 2. Since it is impossible to use a layer of sand as leak detection drainage layer between the two geomembranes on such a steep slope, TENAX CE 204 geonets have been chosen by the design engineer to provide adequate drainage and mechanical protection. These geogrids are only 5 mm thick, but are capable of draining the same quantity of water as 0.50 m of sand.

Anchored, together with the geomembranes in the trenches on top of the slopes, these geonets allow the side slopes to be built with the maximum inclination that is compatible with the stability of the soil below. This method will gain much greater tank volume. A traditional solution, e.g. with a sand and small gravel layer, joined to the TENAX CE 204 geonet as shown in Fig. 2, has been chosen for the drainage on the bottom of the landfill. No particular problems have arisen in the execution of the project, which was carried out with machinery normally used at construction sites. Before placing the geomembranes, the slope has been smoothed with a thin layer of sand. Extrusion-welding of the two overlapped edges has been used for geomembranes seaming. Control of the welding has been carried out by an ultra-sonic method which turned out to be rather slow and complicated, even though no particular problems arose.

TENAX CE 204 geonets have been connected together by tying them with plastic strings. During the testing period, even during heavy rain, no water reached the control well connected to the leak detection drainage layers, therefore guaranteeing the perfect waterproofing of the primary geomembranes.

Conclusions

Through the use of TENAX geonets for drainage along the landfill slopes, the following advantages have been achieved compared to traditional drainage with sand:

- An increase in the available volume for storage of waste equal to 0.25 m³ for each m² of geonet (Fig. 1);
- A great saving in the supply of materials and in the building costs;
- Protection of the geomembranes during building and during disposal for waste materials;
- Higher safety factor against slope veneer stability failure along the smooth HDPE geomembranes.